



Technical data

- Nominal torque: up to 500 Nm, bidirectional
- Rotational speed: ≤ 5.000 rpm
- Accuracy: $\leq \pm 1$ %
- Temperature range: -40 °C to $+85$ °C
- Protection class: IP50
- Output signal: 0-5 V
- Cut-off frequency: 1.000 Hz

Your advantages

- Made in Germany
- Short Lead time (< two weeks)
- Best price-performance ratio
- Integrated electronic (Plug & Play)
- Contactless measurement system
- Including 5 m cable and calibration certificate
- Suitable accessories (Bracket, Readout unit, Couplings)

Short description

The series 2000 is the most easy and affordable entry into torque measurement technology.

This series is mainly used in testing facilities, automation process, production lines e. g. end-of-line tests and Research and Development.

Transmitted torque can be measured statically and dynamically in real time. The series 2000 sensor is available as two variants, with square shaft (Series 2100) and round shaft (Series 2200). Series 2000 offers a 0-5 V output signal.

The sensor is provided as a complete unit with integrated evaluation electronic, including 5 m cable, keystones for Round shaft and calibration certificate.

Model series 2000

Model series 2100 square shaft	Nominal torque [Nm]	Limiting torque unidirectional [Nm]	Limiting torque bidirectional (+/-) [Nm]	Rotational speed [rpm]
¼ inch	2,5	2,5	2,5	1.000 ¹
	5,0	5,0	5,0	
	7,5	7,5	7,5	
	17,5	17	10	
⅜ inch	75	60	40	
½ inch	175	140	85	
¾ inch	500	400	270	

Note: Please note that the series 2100 sensor variants are calibrated to Nominal torque, however, the absolute operational limits for unidirectional and bidirectional loads are as per mentioned in the table above. Do not exceed the mentioned magnitude of limiting torques for unidirectional and bidirectional load.

Model series 2200 round shaft	Nominal torque [Nm]	Limiting torque unidirectional [Nm]	Limiting torque bidirectional (+/-) [Nm]	Rotational speed [rpm]
Ø 9 mm	2,5	3,25	3,25	5.000
	5	6,5	6,5	
	7,5	9,75	9,75	
	17,5	19,5	19,5	
Ø 14 mm	75	97,5	97,5	
Ø 19 mm	175	227,5	227,5	
	250	325	325	
Ø 25 mm	500	650	650	

Note: In case of overload, the sensor leads to an offset in measurement. In such case, the sensor needs to be recalibrated at NCTE AG. The sensor should be operated only within the specified nominal torque range.

¹ Higher speed possible in clearance-free adaption.

Load characteristics

Model series 2100 measuring range	Unit	Axial force [N] ²	Lateral limit force [N]	Bending limit moment [Nm]
2,5 and 5	[Nm]	1.000	20	2,5
7,5		1.000	30	3,7
17,5		1.000	100	12,5
75		2.600	300	41,7
175		4.000	500	89,5
500		7.000	800	176

Model series 2200 measuring range	Unit	Axial force [N] ³	Lateral limit force [N]	Bending limit moment [Nm]
2,5 und 5	[Nm]	1.000	20	2,5
7,5		1.000	30	3,7
17,5		1.000	100	12,5
75		2.600	300	41,7
175 and 250		4.000	500	89,5
500		7.000	800	176

Each type of irregular stress can only be permitted with its given limit value (bending moment, lateral force or axial force, exceeding the nominal torque) if none of the others can occur. Otherwise the permitted limits must be reduced. If for instance 30 % of the limited bending moment and also 30 % of the limited lateral force are present, only 40 % of the limited axial force are permitted, provided that the nominal torque is not exceeded.

² The specified values only apply to direct axial force on the shaft. If the axial force acts on the circlip, only 50% of the force is permitted.

³ The specified values only apply to direct axial force on the shaft. If the axial force acts on the circlip, only 50% of the force is permitted.

Technical characteristics

No.	Model	Unit	Series 2000
	Accuracy class ⁴		1,0
		Unit	Value
1	Linearity deviation incl. hysteresis	%ME ⁵	< ±1,0
2	Rotational Signal Uniformity (RSU)		< ±1,0
3	Repeatability		< ±0,05
Output signal in general		Unit	Value
4	Frequency range, -3dB point, Bessel characteristics	Hz	1.000
5	Analog signal	V	0 ... 5
6	Signal at torque = Zero ⁶	V	2,5
7	Signal at positive nominal torque ⁵	V	4,5
8	Signal at negative nominal torque ⁵	V	0,5
9	Calibration parameter (normed) ⁵	mV/N m	Refer to Calibration certificate
10	Output resistance	Ω	50
Effect of temperature		Unit	Value
11	Zero point drift over temperature	%/10 K	< 0,5
12	Signal drift over temperature within nominal temperature range	%/10 K	< 0,5
Power supply		Unit	Value
13	Supply voltage	VDC	6 ... 15
14	Current consumption (max.)	mA	10
15	Start-up peak	mA	< 40
16	Absolute max. supply voltage	VDC	18
General information		Unit	Value
17	Protection class according to EN 60529 ⁷	IP	50
18	Reference temperature	°C	+15 ... +35
19	Operational temperature range	°C	-40 ... +85
20	Storage temperature range	°C	-40 ... +85

⁴ The accuracy class implies that taken separately both the linearity deviation as well as the rotational signal uniformity are either lower than or equal to the value of the accuracy class.

⁵ %ME: related to a full scale measurement range.

⁶ Please check the exact data at the sensors calibration certificate.

⁷ Wiring connected.

	Nominal torque (bi-directional) Square shaft	Nm	2,5	5	7,5	15	60	140	400	
21	Weight	g	395	401	414	652	754	878		
22	Moment of inertia	g mm ²	582	648	904	3.339	13.294	57.770		
	Nominal torque (bi-directional) Round shaft	Nm	2,5	5	7,5	15	75	175	250	500
23	Weight	g	386	392	400	685	856	1.230		
24	Moment of inertia	g mm ²	597	662	1.073	4.922	19.126	79.754		

Dimensions

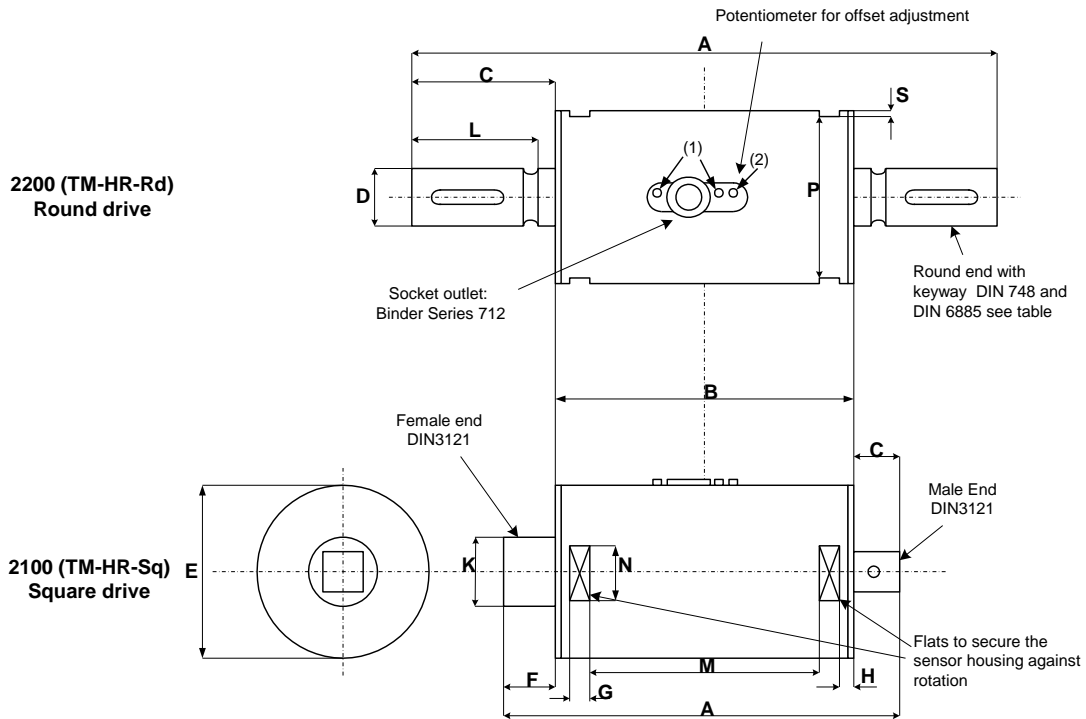

Do not loosen or tighten the mounting nuts of the socket and the lock screws.

Dimensions	Series 2100 Square shaft Nominal torque [Nm]				Series 2200 Round shaft Nominal torque [Nm]			
	1/4 inch	3/8 inch	1/2 inch	3/4 inch	∅ 9 mm	∅14 mm	∅19 mm	∅25 mm
Nominal torque [Nm]	2,5 - 5 - 7,5-17,5	75	175	500	2,5 - 5 - 7,5-17,5	75	175-250	500
A	95,5	107	123,5	146	125	139	179	220
B	70	70	70	87	70	70	70	87
C	9,5	13	18,5	29,6	27,5	34,5	54,5	66,6
D	-	-	-	-	9k6	14k6	19k6	25k6
E	40	50	50	60	40	50	50	60
F	16	24	35	29,6	-	-	-	-
G	8	8	8	10,5	8	8	8	10,5
H	5	5	5	2	5	5	5	2
K	12	18	24	33,5	-	-	-	-
L	-	-	-	-	23	30	50	≅ C
M	43,9	43,9	43,9	61,4	43,9	43,9	43,9	61,4
N	15	18	18	19	15	18	18	19
P	37	47	47	57	37	47	47	57
S	1,5	1,5	1,5	1,5	1,5	1,5	1,5	1,5

Series 2200

Round shaft	Dimensions keyway [mm]			Keystones		
	Width	Depth	Length	Height	Length	Amount
∅ 9 mm	3	1,8	18,5	3	18	1
∅ 14 mm	5	3	25,5	5	25	1
∅ 19 mm	6	3,5	45,5	6	45	1
∅ 25 mm	8	4	50,5	7	50	2

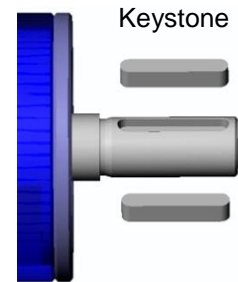

In the case of high alternating loads, torque transmission through a positive and frictional connection with the shaft via a suitable fit or a coupling is recommended.

Connection plan

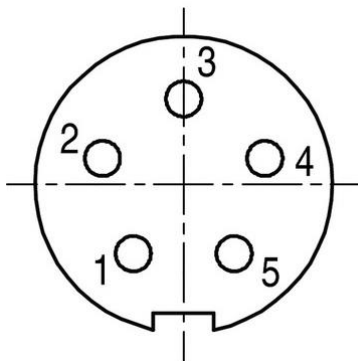

Connector
Power supply and outputs

Binder series s712-M9 connector IP67 colour coding according to DIN 47100			
Type	Colour	Pin	Value
1	White	Supply Voltage V_{CC}	6 V – 15 V
2	Brown	Signal Output analogue	-
3	Black	Ground GND	-
4	Blue	Not used	-
5	Grey	Reference Voltage V_{ref}	2,5 V

The output V_{ref} is a constant 2.5 V and represents the virtual zero point for direct +/- torque measurement.

Connection example:

Connection for measurement between 0,5 ... 4,5 V
e.g. 2.5 V equals to approx. 0 Nm.

Grey and blue wires are not in use.

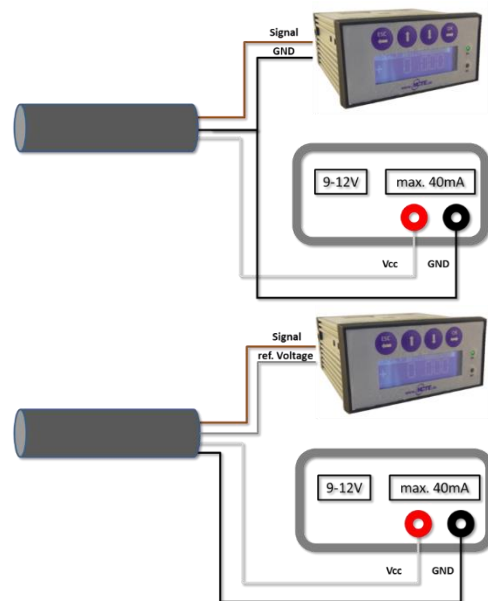

Connection for measurement between - 2,0 ... + 2,0 V
e.g. 0 V equals to approx. 0 Nm.

Blue wire is not in use.

Order options

Series 2100 accuracy 1 % : Square shaft

Measurement range	
2,5	Nm including 5 m cable and calibration certificate
5	Nm including 5 m cable and calibration certificate
7,5	Nm including 5 m cable and calibration certificate
17,5	Nm including 5 m cable and calibration certificate
75	Nm including 5 m cable and calibration certificate
175	Nm including 5 m cable and calibration certificate
500	Nm including 5 m cable and calibration certificate

Series 2200 accuracy 1 % : Round shaft

Measurement range	
2,5	Nm including 5 m cable and calibration certificate
5	Nm including 5 m cable and calibration certificate
7,5	Nm including 5 m cable and calibration certificate
17,5	Nm including 5 m cable and calibration certificate
75	Nm including 5 m cable and calibration certificate
175	Nm including 5 m cable and calibration certificate
250	Nm including 5 m cable and calibration certificate
500	Nm including 5 m cable and calibration certificate

Please feel free to contact your Sales representative Serial products for additional information.
Phone: +49 89 66 56 19 30 or Email: sales@ncte.de

Series 2000 accessories

Sensor bracket



1	2,5 – 17,5 Nm (Ar. Nr.: 400006081)
2	75 – 250 Nm (Ar. Nr.: 400006082)

Readout Unit



1	Order number 400010-ATS001 (Ar. Nr.: 400010005)	The NCTE Read Out Unit is a multifunctional readout unit dedicated for the NCTE torque sensors. Torque, angle or speed can be displayed. The measurement data can be stored on an inserted SD flash memory card or sent directly to a PC computer via USB interface in real time.
---	--	---

Couplings



Coupling types	Used for	D2 max.
KB2/45-41-9-D2	2000 – D9	16
KB2/100-47-9-D2	2000 – D9	25
KB4C/18-59-9-D2	2000 – D9	25,4
KB4C/80-78-14-D2	2000 – D14	42
KB4C/200-83-19-D2	2000 – D19	45
KB4C/300-94-19-D2	2000 – D19	60
KB4C/500-100-25-D2	2000 – D25	70

Please feel free to contact your Sales representative Serial products for additional information.
Phone: +49 89 66 56 19 30 or Email: sales@ncte.de

Instructions for use

Scope of delivery

The torque sensor set consists of the sensor itself (signal pick-up and signal processing integrated into sensor housing), one connecting cable 5 m with a soldered plug (binder plug no. 99-0426-10-08), key stones (round shaft) or square sleeve (Square shaft) and the calibration certificate.

Datasheets and instruction manuals are available at <https://ncte.com/en/standard-products/#>

Installation and removal

It must be ensured that when mounting the sensor, the measuring shaft is exactly aligned with the connecting shafts (corresponding couplings can be found in the accessories). The key adapters / square ends of the connecting shafts must then be able to be pushed onto the key adapter connections / square connections of the sensor without any effort. When fastening, no force may be exerted on the housing in the axial direction. The key surfaces are to be used to secure the sensor against twisting (optional sensor holder). The cable length may be max. 5 m. If a cable other than the one supplied by NCTE or the same cable with a different cable length is used, the function of the sensor system may be impaired.

Do not remove the shaft with torque applied to the sensor.

Interface description

Mechanical connection:

The key stone adapters on both ends of the measurement shaft are intended for torque transmission.

Electrical connector:

On the sensor housing there is a socket for the power supply and the signal output (see chapter connection plan).

Operation (in regular case or in optimal case)

Optimal measurement parameters can be achieved if the sensor is applied in accordance to the specification. By compliance with the specification the sensor works generally trouble-free and maintenance-free.

Irregular operation, measures against disturbance

The mechanical overload on the sensor (e. g. exceeding of maximum allowed torque or severe vibrations) may cause damage to the sensor and in consequence the incorrect signal output. In such cases please do not open the sensor. Contact NCTE directly for assistance.

Commissioning

After sensor installation pay attention to the following:

- Switch on the power supply and check the voltage value (voltage peaks on the sensor must be avoided, devices must be checked accordingly before connection to the sensor).
- Connect the sensor to the power supply unit by using the delivered cable.
- Connect the sensor output to a high-resistance device such as an A/D converter, oscilloscope, pc measurement board.
- The sensor should be in mechanical unloaded state while connecting it.

Shaft coating

The shafts are protected on both sides with a film of anticorrosion wax. We recommend to leave the protection permanent. As far as technologically needed, the coating can be removed with spirit / ethanol

Handling and transportation

During handling, storage and transportation, make sure that the sensor is not exposed to strong magnetic or electromagnetic fields (e.g. demagnetizing coils).

Precautions

- Do not open the sensor housing under any circumstances.
- The shaft locking rings on the shaft ends must not be loosened.
- The fastening nut of the plug (see chapter Dimensions) must not be loosened or tightened.
- Only use voltage supplies that are separate from the mains voltage.
- With regard to the electrical and mechanical load on the sensor, the specifications in accordance with the sensor-specific rating plate and the table in (Chapter: Technical characteristics) must be observed.
- The sensor is not to be used as a support bearing. The existing mounting options are only used to secure the housing against turning.
- To protect your system, we recommend increasing the torque over several stages.

Service and maintenance

As part of your test and measurement equipment management, we recommend regular inspection of your test and measurement equipment. Please also note the relevant standards and guidelines.

Recommended maintenance plan by NCTE

Recalibration	12 month
Inspection of wiring, plug and shaft	12 month

Service-Hotline: Tel.: +49 89 66 56 19 30
 Email: sales@ncte.de

Disposal

For disposal the Sensor has to be returned to **NCTE AG, Raiffeisenallee 3, 82041 Oberhaching, Germany.**