DATUM ELECTRONICS

M425 TORQUE TRANSDUCER

PRODUCT OVERVIEW





THE DATUM M425 TORQUE TRANSDUCER

The latest technology Datum Electronics Series M425 non-contact rotary Torque Transducers have been designed to fit with most applications and solutions requiring rotary torque measurement. The Torque Transducer fits in line with the drive train or test bed, using standard keyway shafts.

A non-contact transmission system provides data directly proportional to torque. In this variant it is supplied as a complete transducer with bearings to support the stator unit on the rotating shaft. It is suitable for most general test rig applications.

The M425 Torque Transducer utilises a strain gauged shaft for accurate and reliable torque measurement and a set of rotating on-shaft conditioning electronics. The digital signals are transmitted to the non-rotating part of the system or stator providing a reliable and highly accurate torque measurement solution.

The M425 has a torque measuring element design with an optimum length to maximise overall accuracy and give a high degree of tolerance to mounting offset.

The M425 also has a legacy mode so that it can be used as a direct replacement for the previous M420 Transducer.

M425 SYSTEM PERFORMANCE AND BENEFITS:

Ranges 0-10Nm up to 0-60,000Nm

High resolution torque sampling

High data rate

Accuracy and resolution options

Non-contact data transmission

Static and rotary torque measurement

Operational stability

Magnetic speed sensor - not effected by dirt

Simple to integrate

Robust construction

Sample rate selection 1-4000 samples per second

Low power consumption

SPECIFICATIONS

M425 PERFORMANCE INFORMATION

PERFORMANCE

Non-Linearity	+/-0.1% FSD
Non-Repeatability	+/-0.05% FSD
Noise-free Resolution	20 bit to 13.5 bit (dependent on sample rate)
Sample Rate	1 to 4000 samples per second
Output Baud Rate	9600 to 3Mbaud

RPM:	
Size 1 to 6	30 pulses per rev

Transducer output interfaces:	
Serial data via RS485	
RS232 (option)	

Transducer output data:			
Torque	Shaft RPM	Shaft Temp.	Diagnostics

POWER SUPPLY	
Transducer	10-24Vdc 250mA
Transducer and Interface	15-24Vdc 400mA

ENVIRONMENT	
Thermal Stability of Gain per 10°C	0.02%
Thermal Stability of Zero per 10°C	0.02%
Normal Specification Range	10 to 60°C
Operating Range	-10 to +70°C
Storage Range	-35 to +75°C
Environmental Protection	IP54 (see RS425 for IP67/68 options)
Electromagnetic Compatibility	EN61326-1:2006 (IEC61000-4), IEC60945)

For signal output options including Ethernet, MODBUS, USB, RS485/232 and 4 analogue channels configured 4-20mA (4-12-20mA): +/-10Vdc, +/-5Vdc, 0-10Vdc or 0-5Vdc, refer to Document 1013 Datum Universal Transducer Interface.

Document: 1012 Issue: 5 Date: 03/08/2016

M425 model size	Rated load (Nm)	Rated load (Lbft)	Standard max RPM	Overall length (mm)	Moment length	Bending loads at the moment length (N)	Shaft proof load (Nm)	Shaft ultimate (breaking) load (Nm)	Axial loads (N)	Total stiffness (Rad/Nm)	Total stiffness (Nm/Rad)
Size 1 - A	10	7.4	0-10,000	184	154	8	18	32	442	2.06E-03	485
Size 1 - B	20	14.8	0-10,000	184	154	14	31	55	636	1.12E-03	891
Size 1 - C	50	36.9	0-10,000	184	154	33	74	131	1,131	5.25E-04	1,904
Size 1 - D	100	73.8	0-10,000	184	154	65	144	257	1,767	3.62E-04	2,761
Size 2 - A	250	184	0-8,000	240	175.5	153	389	694	3,431	6.09E-05	16,418
Size 2 - B	500	369	0-8,000	240	175.5	330	838	1,497	5,726	3.74E-05	26,749
Size 3 - A	1,000	738	0-6,000	315	132.75	797	1,530	2,732	8,553	1.07E-05	93,458
Size 3 - B	2,000	1,475.1	0-6,000	315	132.75	1,644	3,155	5,633	13,854	4.99E-06	200,573
Size 4 - A	5,000	3,687.9	0-5,000	425	218.75	2,364	7,477	13,353	24,630	2.22E-06	450,056
Size 4 - B	10,000	7,375.7	0-5,000	425	218.75	4,618	14,604	26,079	38,485	1.27E-06	789,591
Size 5 - A	15,000	11,064	0-2,000	416	191	8,502	23,477	41,922	52,810	3.82E-07	2614,430
Size 5 - B	20,000	14,751	0-2,000	416	191	11,241	31,040	55,428	63,617	2.95E-07	3390,520
Size 5 - C	25,000	18,439	0-2,000	416	191	14,513	40,075	71,562	75,430	2.39E-07	4185,528
Size 5 - D	30,000	22,127	0-2,000	416	191	17,851	49,290	88,018	86,590	2.06E-07	4863,152
Size 6 - A	40,000	29,503	0-1,500	410	185	21,190	56,672	101,200	95,033	1.67E-07	5986,531
Size 6 - B	60,000	44,254	0-1,500	410	185	34,977	93,545	167,045	132,732	1.25E-07	8021,991

Bending loads

Diagram No. 15

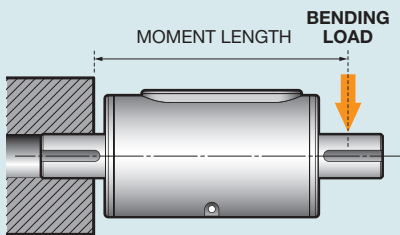

Where possible moments at the end on the shaft should be avoided. The table contains values for the moments that can be exerted without damage with the transducer not rotating. These values should be reduced if the shaft is rotating.

Axial loads

Diagram No. 16

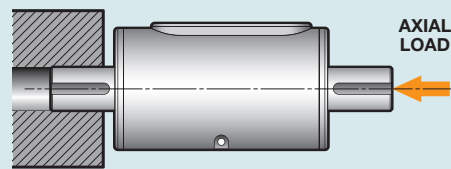

Direct Axial loads will have little effect on performance, however offset Axial loads that apply a cross moment to the shaft will have an effect on the smaller size 1 transducers below 50Nm and should be avoided.

M425 Specifications

	A	B	C	D	E	F	G	H	I	J	
M425 model size	Overall length	Body length	Body dia.	Output module length	Output module height	Exposed shaft length	Shaft dia. G6 fit	Number of keyways	Keyway length (BS 4235-1:1972)	Keyway width (BS 4235-1:1972)	Keyway depth off centre
Size 1 - A	184	130	66	112	3.5	27	15	1 keyway	22.5	5	4.3
Size 1 - B	184	130	66	112	3.5	27	15	1 keyway	22.5	5	4.3
Size 1 - C	184	130	66	112	3.5	27	15	1 keyway	22.5	5	4.3
Size 1 - D	184	130	66	112	3.5	27	15	1 keyway	22.5	5	4.3
Size 2 - A	240	150	85	112	3.5	45	30	1 keyway	44	8	11
Size 2 - B	240	150	85	112	3.5	45	30	1 keyway	44	8	11
Size 3 - A	315	150	110	112	5.5	82.5	50	1 keyway	78.5	12*	20
Size 3 - B	315	150	110	112	5.5	82.5	50	1 keyway	78.5	12*	20
Size 4 - A	425	150	135	112	5.5	137.5	75	1 keyway	78.5	20	30
Size 4 - B	425	150	135	112	5.5	137.5	75	1 keyway	78.5	20	30
Size 5 - A	416	168	170	112	5.5	124	110	2 keyway	116	32	44
Size 5 - B	416	168	170	112	5.5	124	110	2 keyway	116	32	44
Size 5 - C	416	168	170	112	5.5	124	110	2 keyway	116	32	44
Size 5 - D	416	168	170	112	5.5	124	110	2 keyway	116	32	44

Model size	A	B	C	D	E	F	K	L	M	N & O
Total mass Kgs	44.93	44.93	44.93	44.93	44.93	44.93	44.93	44.93	44.93	44.93
Rotor mass Kgs	31.842	31.842	31.842	31.842	31.842	31.842	31.842	31.842	31.842	31.842
Output module length	416	416	416	416	416	416	416	416	416	416
Output module height	416	416	416	416	416	416	416	416	416	416
Exposed shaft length	416	416	416	416	416	416	416	416	416	416
Spline outer dia.	152.4	152.4	152.4	152.4	152.4	152.4	152.4	152.4	152.4	152.4
Spline inner dia.	137	137	137	137	137	137	137	137	137	137
Spline no.	6 spline	6 spline	6 spline	6 spline	6 spline	6 spline	6 spline	6 spline	6 spline	6 spline
Chamber and radius	N=0.5-1, O=1.1-1.3	N=0.5-1, O=1.1-1.3	N=0.5-1, O=1.1-1.3	N=0.5-1, O=1.1-1.3	N=0.5-1, O=1.1-1.3	N=0.5-1, O=1.1-1.3	N=0.5-1, O=1.1-1.3	N=0.5-1, O=1.1-1.3	N=0.5-1, O=1.1-1.3	N=0.5-1, O=1.1-1.3

Alphabet key for M425

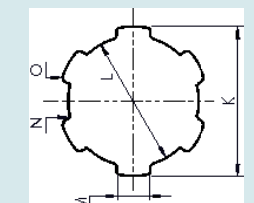
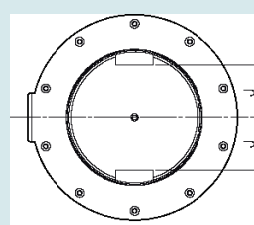
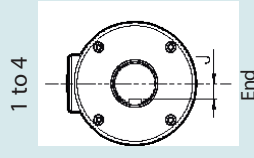
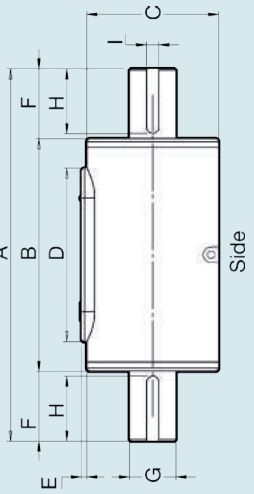
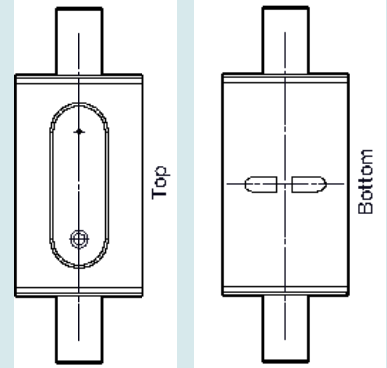

*Does not comply with BS 4235-1:1972

ALTERNATE CONNECTION OPTIONS

The M425 is compatible with a variety of other universal interfaces or indicators by correct cable and PIN configuration. This allows direct connection to their user software and customers own software. See page 7 of the M425 handbook for a guide to wiring connector configuration.

The M425 will also accept configuration commands to enable connection to legacy Datum Electronics interfaces and indicators. When set in compatibility mode the M425 can be used with Torque Log Software, the Datum Electronics type 300 and Type 370 Indicators and the Type 400150 USB / analogue or 400152 USB interfaces.



DATUM ELECTRONICS LIMITED
TELEPHONE: +44 (0) 1983 28 28 34
FAX: +44 (0) 1983 28 28 35
EMAIL: support@datum-electronics.co.uk
WEB: www.datum-electronics.co.uk